

<b>payphone.com</b> Quality. Selection. Value.	Global Supplier of Public Telecommunications Equipment 
<b>G-TEL</b> Enterprises, Inc.	16840 Clay Rd. #118 Houston, TX 77084 USA Toll Free 1-800-884-4835 International 281-550-5592

**Owners Manual: G-Tel 525(Wire-line)**



**Getting started:**

1. Connect the phone's RJ11 phone jack to the local telephone line.
2. Lift hand-set, listen for dial tone, LCD will display "PLEASE DIAL".
3. Dial desired number.
4. Deposit coins per display. When insufficient coins are deposited, the right side of LCD will flash the amount needed to place the call.
5. When called party answers, the phone will auto collect coins and begin to count down, the right side of the LCD will display the balance, the left side will display the available time you can talk.
6. When the available talk time approaches 30 to 15 seconds, the phone shall emit a warning tone. This means that you must insert coins to extend the call. The amount needed shall be displayed on the right of the display. If no coins are deposited by the time the counter expires, the call shall be cut off.
7. During incoming calls, the available talk time is displayed on the screen. If there is a charge to receive incoming calls, the amount will be displayed on the LCD.

8. Once the cashbox password has been programmed you may check the cashbox at any time. Pick the up receiver, dial \*# and 8 digit password, the phone shall display the current cashbox amount.
9. As the owner of the payphone you are able to place free calls using the owner's password. Pick up the receiver, dial \*# and the 8 digit owner's password.

**Attention:** While in program mode, the payphone will pause and re-flash the telephone line. This will prevent the local phone company from cutting-off dial tone to the phone. During this pause, the phone will not recognize any digits dialed.

**Dial \*** to cancel operation and return to previous command mode.

**Dial #** to confirm the change.

**Dial 1** to move to the next location.

**Dial 2** to scroll through the selected location.

**Dial 4** to move to the previous location.

### **Accessing program mode:**

Lift receiver, dial \*# and eight digits as programming password (factory default is 88888888). The LCD should display "PROGRAM (00-24). The following instructions are under the assumption that the phone is in program mode.

### **List of setup options:**

- A) 01: Password programming.
- B) 09: Tariff rate programming
- C) 10: Prefix code programming
- D) 07: Incoming Call options.
- E) 05: Coin calibration.

F) 15: Free hotline programming.

G) 24: Call restrictions.

H) 04: Coin collection options.

I) 12: Coin box.

J) 00: Self Diagnosis.

K) 02: Line type select.

L) 03: Tone/Pulse option.

M) 04: Answer Detect.

Troubleshooting Steps

Phone Reset

### **A) Function 01: Password programming**

1. Dial "01", the LCD will display "OWNER p:"

a. The 1<sup>st</sup> option is allows the owner to create a password to dial out for free. The password must be 8 digits long. Dial # after your pass-code to save.

b. When you wish to make a free call, lift the handset, listen for dial tone and dial \*# (your pass-code). The phone will know let you dial out for free.

2. "FUNC p:" is the set password for entering the program mode. You may change the pass-code if you wish, the factory default is 88888888.

3. "CASHB p" is the cashbox password. The pass-code allows the owner check the cashbox total from the keypad. Enter 8 digits and # to save. The phone will return automatically to the main menu: "PROGRAM (00-24)"

**NOTE:** Please record the **FUNCTION** pass word, it cannot be reset.  
 With out the password you will not be able to enter the program mode.  
 The phone will have to be sent in for service.

**B) Function 09: Tariff rate programming**

1. Tariff rates and Prefix designations are directly related. Prefixes programmed in AREA (01) will be assigned to RATE (01); AREA (10) will be assigned to RATE (10). The table below displays the direct relation:

<b>RATE</b>	<b>← →</b>	<b>AREA</b>
50c/60s Digit: 11	01	(empty)
50c/60s Digit: 11	02	(empty)
75c/60s Digit: 11	03	555
50c/60s Digit: 08	04	1411,411,1555
25c/180s Digit: 10	05(Local)	2,3,4,5,6,7,8,9
50c/60s Digit: 11	06 (LD)	1
25c/180s Digit: 11	07	(empty)
00c/60s Digit: 11	08	1800
00c/60s Digit: 09	09	1010
50c/60s Digit: 11	10	(empty)
etc	.....	Etc
50c/60s Digit: 11	24	(empty)

2. Dial "09", the LCD will display "R01: 50c/60". Use the "1" key to move forward or the "4" to move to the previous location. There are a total of 24 tariff rate bands.
3. The screen will display R01: 50c/60s. Press key "1" and scroll to R05: 25c/180s, this is your local call rate setting.
4. The current rate is 0.25 cents for 3 minutes. To change the rate dial #, you will see a prompt to enter your desired values. You must enter 0 followed by the desired coin amount. For example, 0050 means 0.50 cents.
5. Next, you will be directed to the initial time setting. Time is set using seconds instead of minutes. For example, 120s means 2 minutes, 060s stands for 1 minute. You must enter 3 digits for your initial time.
6. Once you have entered the initial time, the phone will save the new values.
7. Next, the phone will ask for the number of digits that you must dial to make a local call. For example, a 10 digit local number is 281-550-5592. If your location offers 7 digit dialing, press key 4 until 07 is selected. Press # to save your local dialing setting.
8. Long distance rates are located in band R06: 50c/60s. Repeat steps 4 and 5 if you wish to change the values.
9. If you would like to change the information rates, they are located in bands R03 and R04. Repeat steps 4 and 5 to make the desired change.
10. Each rate band also has a price for additional time. From default, the payphone sets the additional time like those of the initial charges. For example, if your initial charge for a local call is \$0.25 for 5 minutes, the phone will charge \$0.25 for an additional 5 minutes automatically.
11. To set the additional time for a call, scroll to the appropriate rate band and dial "9". The screen shall display "XXc / XXs", which should be identical to the initial charges. Dial # to edit the rate and time, the phone will

automatically save the change and return to the initial charge screen of that rate band.

**Example 1:**

Initial charge of \$1.00 for 4 minutes and \$0.50 for an additional 2 minutes; Dial “9” to display the additional rate, dial # to enter the new rate. The LCD will display “■ 50c/60s”, enter 0050 for the amount, 120 for the time, the phone will return to the main tariff rate. Dial #, the LCD will display “Rxx: ■ 50c/60s”, enter 0100 for the charge, 240 for the time. The phone will automatically save and proceed to the “MAX DIGIT: XX” setting. “XX” stands for the digit limitation for this group. You can program the dialing via keys “1” and “4”, control range is 3-40 digits.

**C) Function 10: Phone prefix code programming**

The payphone determines the price of each call by the first few digits of a number, known as a prefix. In default mode numbers beginning with 2, 3, 4, 5, 6, 7, 8, and 9 that are 10-digits or less in length are considered a local call (A05). Numbers that start with 1 are considered long distance (A06) excluding toll free numbers: 281-550-5592 → local call, while 1-281-550-5592 → long distance call

In some areas you may have to dial “1+ (area code) + number” to dial a local call. You may also have toll rates for some numbers and not others. You may use areas 10 through 24 to program the phone to recognize these prefixes, there are a total of 24 locations in which you may store prefixes.

RATE	← →	AREA
50c/60s Digit: 11	01	(empty)

50c/60s Digit: 11	02	(empty)
75c/60s Digit: 11	03	555
50c/60s Digit: 08	04	1411,411,1555
25c/180s Digit: 10	05(Local)	2,3,4,5,6,7,8,9
50c/60s Digit: 11	06 (LD)	1
25c/180s Digit: 11	07	(empty)
00c/60s Digit: 11	08	1800
00c/60s Digit: 09	09	1010
50c/60s Digit: 11	10	(empty)
etc	.....	Etc
50c/60s Digit: 11	24	(empty)

1. Dial "10", the LCD will display "A (01): XXXX". Use keys "1" and "4" to navigate through the locations. You may dial "2" to review multiple prefixes that are stored in each location.
2. Each of the 24 locations can hold up to 16 7-digit prefixes.
3. A01 and A02 are available for prefix programming.
4. A03 and A04 are the locations used to define local and long distance information patterns.
5. A05 holds the local call number prefixes. A06 holds the long distance definition.
6. A08 holds the 1800 number prefixes while A09 contains the 1010 prefix.
7. A10 – A24 are available for addition prefix definitions.

**NOTE:** The factory default settings will work in almost all locations within the U.S. There is no need to modify these settings when first installing the phone.

To clear a memory location you may dial #, the LCD shall display "PREFIX:" dial # once more. The LCD shall display "DELETE....ALL?" dial # one last time to delete all prefixes in the memory location. If you entered the incorrect memory location, you may dial \* at any time to return to the beginning.

**Example:**

- **A(05) # dial 2# 3# 4# 5# 6# 7# 8# # . This example defines all the prefixes that are considered local calls. The phone will now charge prefixes 2-8 as the R05 rate band.**
- **A(06) # dial 1# #. This example defines prefix 1 to charge the rate under R(06)**
- **FREE # dial 1855 #, 281# #. By defining these prefixes in the "FREE" location, numbers that start with 1855 or 281 shall have no charge.**
- **A(06) # dial # #, this shall delete the stored prefix 1, blocking all long distance.**

**D) Function 07: Incoming calls**

1. You can decide between free incoming, denying or charging for the incoming call.
2. Dial 07 to access the incoming call menu. The factory preset allows for free incoming calls.

3. The left column is the free time allowed before the phone will charge for the incoming call. By using the 1 and 4 keys, you may increase or decrease the time allowed, for example: 0s means blocked, 999s means unlimited time.
4. The middle column stands for the price the phone will charge after the free time has expired. Press the 2 and 5 keys to increase and decrease the charge. You may set the talk time from 1 second to 999 seconds. Use keys 3 and 6 set your desired values.
5. Once complete, dial # to save.

**Example: 30s, 25c/180s.**

This setting states that the first 30 seconds of the incoming call is free, afterwards the phone will charge \$0.25 for 180 seconds (3 minutes).

### **E) Function 05: Coin Calibration**

The payphone has the ability to accept up to six different coins. To ensure the best performance, we suggest using at least 15-20 coins of each value:

1. Dial 05 to access the Coin parameter programming.
2. The display will say: (1) \$0.05
3. Dial #, an icon will begin to flash. Enter the desired value for the first coin.
4. The value must be 4 digits long, for example: 05.00, 15.00, 00.50 and 00.05. Once complete dial # to save.
5. Next, the screen will display 12 numbers: "aaa-bbb, ccc-ddd". These are the coin parameters.
6. In this screen deposit the 15-20 coins. The first couple of coins will cause the numbers to change a little bit.
7. Once all coins have been deposited, dial # to save the settings.
8. The screen will automatically switch to (2) \$0.10

9. Press #, an icon will start to flash. Enter the desired value for the second coin.
10. Again, the value must be 4 digits long, for example: 01.00, 10.00, 00.10 and 00.01. Once complete dial # to save.
11. The screen will display 12 numbers: “aaa-bbb, ccc-ddd”
12. In this screen deposit the 15-20 coins.
13. Once all coins have been deposited, dial # to save the settings.
14. Repeat the above steps for the remaining 4) locations if necessary.
15. Once the settings are saved you may hang up.

#### **F) Function 15: Free call programming**

The payphone allows you to program up to 8 free numbers. The number programmed in the second group can be accessed from the Hotline button on the front of the phone. You can use this feature to save a speed dial number.

1. Dial “15”, the LCD will display “HOT line call 1”.
2. To skip a group and move to the next, dial #. The LCD will display “HOT line call 2”
3. Enter a number which you would like to dial for free, dial # to save.
4. Continue to enter numbers until all locations have been used. You may dial \* exit at any time to exit.
5. If you would like to erase a number dial # # to erase that particular group.
6. To access the Hotline number programmed in group 2, lift the handset and press the Hotline button, the display will say “FREE”.

#### **G) Function: 24: Call restriction programming**

The payphone is able to restrict up to 8 different telephone numbers. These numbers can be residential, business or personal numbers which you want to deny the caller from dialing.

**NOTE:** There is no need to enter numbers such as 1976 and 1900 since they are already listed in the **BLOCK** section of **Function 10**.

1. Dial “24” the LCD will display “RESTRICT1”.
2. Dial the number which you would like to restrict (limit 16 digits) and dial # to save.
3. If you would go back and delete a restricted number, proceed to the location of the number by pressing #. When the number is on the screen, press the Volume button on the face, the screen shall prompt “DELETE”, dial # to confirm.
4. Once complete you may dial \* to exit to the main menu.

#### **H) Function 12: Coin box checking**

1. Dial “12”, the LCD will display “\$ XX.XX”
2. \$ XX.XX is the total amount in coin box.
3. Dial “9” followed by “19940410” to reset the coin box amount.
4. Dial \*, the payphone shall return to “PROGRAM (00-24)”

#### **I) Function 13: Language selection**

1. Dial “13” the LCD will display “TEXT: ENGLISH”
2. “ENGLISH” will setup the screen to prompt in English.
3. “SPANISH” will setup the screen to prompt in Spanish.
4. Dial “1” to select the desired language for the phone, dial #. The LCD will display “TIMER: ON”
5. “TIMER” selects whether a counter shall be on the screen as the client speaks on the phone displaying the remaining time.

6. Dial 1 to select your desired option dial # to save the setting and to return to the main menu.

### **J) Function 00: Self diagnosis**

1. Dial "00", the LCD will display "TEST ITEMS (1-3)."
  - a. Dial 1 to check for keypad operation.
  - b. Dial 2 for Photoelectric and inductor test.
  - c. Dial 3 for solenoid operation.

#### Test Step 1:

- a. Dial "1", the LCD will display "KEYPAD".
- b. Dial any digit to check for proper recognition of keypad. Dial \*\* to return to the main test screen.

#### Test Step 2:

- a. Dial "2", the LCD will display "1234 (1816,1678)"
- b. "1234" means the photoelectric cells are working correctly.
- c. If the LCD displays "1x34" the 2<sup>nd</sup> photoelectric cell is defective or obstructed. Under normal operation all 4 digits shall be displayed.
- d. (1816, 1678) are the 1<sup>st</sup> and 2<sup>nd</sup> group parameters for the coin inductors.
- e. Dial \* to return to the main test screen.

#### Test Step 3:

- a. Dial "3", the LCD will display "SOLENOID 1"
- b. The phone shall undergo a brief test of the coin mechanism solenoid to ensure proper operation.
- c. The phone will cycle through solenoid 1 automatically return to the main test menu if everything is in working order.
- d. Dial \* to return to the main program menu: "Program (00-24)"

## **K) Function 02: Line type select**

1. Dial "02", the LCD will display "LINE: PTT"
  - a. The phone is setup for use on a normal POTS telephone line from default. LINE: PTT stands for direct line operation mode.
  - b. If you choose "LINE: PTT", dial # to save the setting and return to the main program menu: PROGRAM (00-24)
2. If the phone will be installed behind a phone system and will need to dial a prefix to call out, select "LINE: PBX"
  - a. If you choose "LINE: PBX", dial # to save the setting.
  - b. The LCD will display "CO DIAL: AUTO" which means that the payphone will automatically dial the selected prefix before each number.
  - c. CO DIAL: MANUAL is for applications where the prefix will be dialed by the caller.
  - d. Dial "1" to select between AUTO and MANUAL. Dial # to save.
  - e. The LCD will display "PBX CO CODE:"
  - f. Input the prefix needed, limit is 4 digits.
  - g. Dial # to save and to return to the main program menu.

**For example: (9) 281-550-5592, (8) 1-800-884-4835**

## **L) Function 03: TONE / PULSE Option**

1. Dial "03" the LCD will display "DIALING: TONE".
  - a. Dial "1", to switch between TONE and PULSE dialing.
  - b. Dial # to confirm the setting and return to the main menu.

## **M) Function 04: Answer detect**

1. Dial "04", the LCD will display "METERING: RESPOND".
  - a. REVERSE sets the phone to look for a change in polarity from the telephone line provider when the call is connected.
  - b. RESPOND sets the phone to detect the human voice to determine if the call is connected.
  - c. Dial "1", to switch between REVERSE and RESPOND.
  - d. Dial # to confirm the setting and return to the main menu.
  - e. If you select RESPOND, "SENSITIVE ADJ: 13" will display on the LCD. This setting adjusts the sensitivity of the phone in detecting the human voice. The higher the value, the lower the sensitivity and vice versa.

**If you experience coin collect issues while trying to place a call follow the steps below:**

1. After dialing, the phone starts to count down before the call is even connected. Increase the SENSITIVE ADJ. Test the payphone to see if the problem has been corrected.
2. If someone answers the line but cannot hear you and there is no counter on the display. Lower the SENSITIVE ADJ.

### **Troubleshooting tips:**

1. Lift handset and there is no dial tone and nothing is displayed on the LCD:
  - a. Check all line connections and make sure the phone line it self is good. You may use a regular phone to check for dial tone on the line.
  - b. Remove the coin box and inspect the grey ribbon cable and ensure that it is connected securely on the inside of the phone.

2. When you lift the handset there is only a buzz emitting from the ear piece:
  - a. Remove the coin box and locate the small reset button located behind the grey ribbon cable. With the phone off-hook, reset the phone. The phone should return to normal operation.
3. Phone always rejects your coins or is not working consistently:
  - a. The phone may need to be re-calibrated, follow the steps under **Function 05** to re-calibrate the coin mechanism.
4. A Warning tone is heard after dialing a number and the LCD displays "INVALID NUMBER". The phone did not recognize the pre-fix dialed. Please check the prefix definitions under FUNCTION 10.

**To restore the phone to default mode:**

1. While in the main program screen "PROGRAM (00-24)", dial 67 and then 89.
2. The LCD will display "PASSWORD:"
3. Dial 8458 and then #.
4. The LCD will display "RESET EPROM?"
5. Dial \* if you wan to cancel and return to the main program menu.
6. Dial # to initialize the default programming.
7. Progress will be displayed as ">>>>>>" on the LCD.
8. Once the LCD displays "OK!" the initialization is complete.
9. After initialization, the original coin parameters are set to default.

## DEFAULT TARIFF RATE SHEET

<b>Owner password</b>	
<b>Password programming</b>	<b>88 88 88 88</b>
<b>Coin box password</b>	<b>99 99 99 99</b>
<b>Coin box Value</b>	<b>\$0.00</b>
<b>Dial out mode</b>	<b>PTT</b> <input checked="" type="checkbox"/> <b>PBX</b>
<b>PBX out line code</b>	
<b>Auto dial PBX out line code</b>	<b>ON</b> <input type="checkbox"/> <b>OFF</b> <input type="checkbox"/>
<b>Dialing mode</b>	<b>TONE</b> <input checked="" type="checkbox"/> <b>PULSE</b> <input type="checkbox"/>
<b>Charge mode</b>	<b>POLARITY REVERSAL</b> <b>RESPOND</b> <input checked="" type="checkbox"/>
<b>Voice detecting parameter</b>	<b>13</b>
<b>Coin collection display</b>	<b>RBT: 1s</b> <b>NRBT:8s</b>
<b>Ring Back tone parameter</b>	<b>RBT: 5s</b> <b>DELAY: 8s</b>

## DEFAULT TARIFF RATE SHEET

<b>Zone</b>	<b>TARIFF RATE</b>	<b>PREFIX</b>	<b>REMARK</b>
<b>Local Calls</b>	<b>\$0.25/180sec.</b>	<b>2,3,4,5,6,7,8,9</b>	<b>Max digits 10</b>
<b>Long distance calls</b>	<b>\$0.50/60sec.</b>	<b>1</b>	<b>Max digits 11</b>
<b>Information calls</b>	<b>\$0.50//calls</b>	<b>1411,411,1555,555</b>	<b>Max digits 8</b>
<b>Long distance information calls</b>	<b>\$0.75/call</b>	<b>1???+555</b>	<b>Max digits 11</b>
<b>Free calls</b>	<b>Free</b>	<b>1800,1855,1866,1877,1888,911</b>	
<b>Restricted calls</b>	<b>Restriction</b>	<b>011,1700,1900,1976,976</b>	
<b>Incoming calls</b>	<b>Free</b>		
<b>Extended local/toll calls</b>	<b>\$0.25/180sec.</b>		
<b>Additional Spare Bands</b>	<b>\$0.50/60sec.</b>		
<b>Spared bands for free calls</b>			
<b>Additional Spared Bands</b>			
<b>Carrier</b>			
<b>Reroute calls</b>			

## Installation:

### Wall mode installation:

Use screws in locations 1,2,3,4 to secure the mounting plate on the wall. Hang the phone with the mounting plate pothook. Remove the coin box and secure the phone using screws in locations 5, 6 to the mounting plate. The installation is complete.

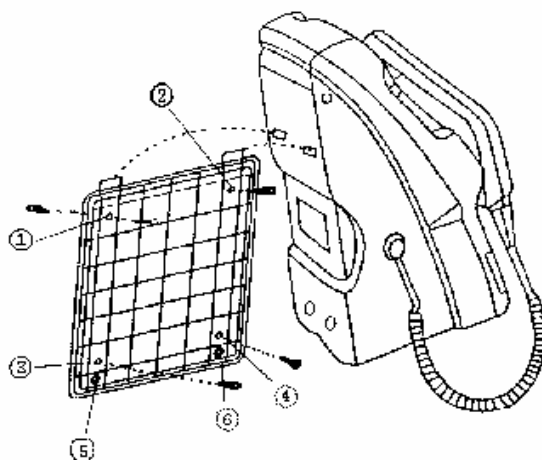

### Desktop Install:

Use screws in locations 1,2,3,4 to secure the mounting plate on the desktop. Secure the phone with the mounting plate pothook. Remove the coin box and secure the phone using screws in locations 5 and 6 to the mounting plate. The installation is complete.

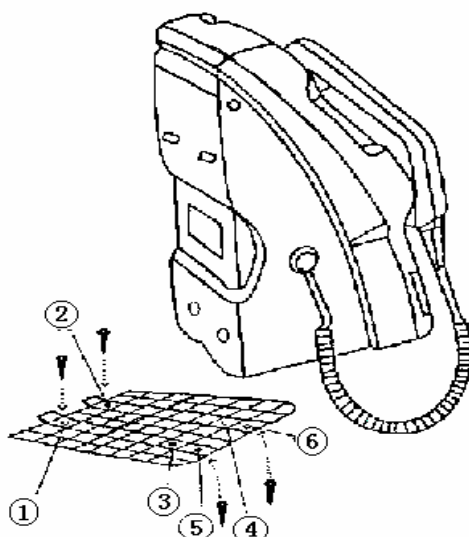



## Technical Support

G-TEL Enterprises, Inc. offers technical support via telephone and Internet only. Before trying to contact G-TEL Technical Support, we strongly advise that you read the portion of the manual related to your support needs so that a technician will be able to better assist you. You can reach G-TEL Technical Support via e-mail at [support@payphone.com](mailto:support@payphone.com) or by phone at 1(800) 884-4835.

## Warranty Policy

### Warranty Policy

G-TEL Enterprises, Inc. - Payphone.com warrants the G-Tel 525 to be free from defects in material and workmanship for a period specified on the product information page found at [www.payphone.com](http://www.payphone.com). This warranty is extended only to the original purchaser. G-TEL shall, at its option, either repair or replace such products and parts which are defective within the warranty period. All return shipments are made F.O.B. G-TEL warehouse, to be paid by the telephone owner. There is no warranty on products that have been modified, adjusted, vandalized, neglected, abused, or improperly operated or maintained. G-TEL's liability under this warranty or any other warranty whether expressed or implied in law or fact shall be limited to the repair or replacement of defective material and or workmanship, and in no event shall G-TEL be liable for consequential or indirect damages, including freight or charges of any kind.

### Disclaimer

G-TEL coin phones have dual functions, as a regular phone and coin phone. Responsibility of type of use, rates and related regulations will be at the sole discretion of the telephone owner, including and federal, state, or local regulations. NOTE: If a phone must be sent in for repair, please include a note with your name, company name, complete address, contact phone number and a full description of the service problem.

### Returns

All returns must be made within 30 days of purchase and is subject to a 25% restocking fee.