

VIKING

TECHNICAL Practice

TELECOM SOLUTIONS FOR THE 21ST CENTURY

**E-30-PT /
E-30-PT-EWP**
*Speaker Phone with
Push To Talk Button*
April 21, 2009

Provide Reliable and Intelligent Communication - In Noisier Locations



E-30-PT/E-30-PT-EWP
shown in optional VE-5x5

The **E-30-PT** is designed to provide quick and reliable communication in noisier areas. The mic sensitivity is set to a low level until the **TALK** button is pressed then it is raised to a normal level. In this way, the **E-30-PT** assures that the called party's voice will be broadcast over the speaker. *In applications where the background noise can be louder than the person calling, a handset type phone is recommended.*

The **E-30-PT** features non-volatile memory, a built in dialer, and intelligent call progress detection for automatic hang-up when the call is completed. The **E-30-PT** can be programmed to dial up to 5 different numbers on ring no answer or busy and can be configured to dial these numbers until answered.

The **E-30-PT-EWP** shares all of the features of the **E-30-PT** in addition to Enhanced Weather Protection (EWP) for installation in harsh environments. EWP products feature rubber gaskets and boots, silicon sealed connections, gel-filled butt connectors, as well as urethane potted circuit boards with weather sealed, field-adjustable trim pots and DIP switches for easy on-site programming.

Features

- Push to talk button
- Phone line powered
- Vandal resistant, stainless steel faceplate with heavy-duty metal call buttons
- Non-volatile E² memory (no batteries required)
- Touch Tone or pulse dialing
- Programmable to dial up to 5 numbers on busy or ring no answer
- Red off-hook LED indicator
- Hangs up on CPC, silence, busy signal, return to dial tone, time out or a Touch Tone command
- Programmable to auto-answer on incoming calls
- Remotely programmable
- Extended temperature range (-15°F to 130°F)
- Flush mountable using included plastic rough-in box
- **E-30-PT-EWP** conforms to NEMA requirements
- **E-30-PT-EWP** has Enhanced Weather protection
- Optional **VE-5x5** surface mount back box

 Need More Information on EWP?
Call (715) 386-4345 and select 859.

 Need More Information on VE-5x5?
Call (715) 386-4345 and select 424.

Applications

Non-ADA Hot-Line Phones for:

- Terminals
- Stadiums
- Parking lots/ramps
- Convention centers
- ATM machines

Gate and Door Entry Phones for:

- Business lobbies
- Vehicular and pedestrian gates
- Residences

CAUTION - When installing on an analog extension of a phone system: Some phone systems do not conform to analog telecom standards and might not be compatible with the E-30-PT phones. For a detailed description of the telephone line specifications required for any of the E-30-PT phones, retrieve Fax Back Document 869.

Specifications

Power: Telephone line powered. Minimum 24V DC talk battery voltage, with a minimum loop current of 20mA loop (room temp), or 25mA (extended cold temp range). Loop current may be boosted on low current lines with a Viking Model **TBB-1** talk battery booster (Fax Back # 630).

Minimum Ring Voltage: 90VAC RMS

Dimensions: Overall-127mm x 127mm x 57mm (5" x 5" x 2.25"), Plastic Electrical Box-102mm x 102mm x 54mm (4" x 4" x 2.12")

Shipping Weight: 1 Kg (2.2 lbs)

Operating Temperature: -26°C to 54°C (-15°F to 130°F)

Humidity - E-30-PT: 5% to 95% non-condensing

Humidity - E-30-PT-EWP: Up to 100% condensing

Connections - E-30-PT: RJ11 jack

Connections - E-30-PT-EWP: Gel-filled butt connectors

Phone...715.386.8861

Installation



IMPORTANT: Electronic devices are susceptible to lightning and power station electrical surges from both the AC outlet and the telephone line. It is recommended that a surge protector be installed to protect against such surges. Contact Panamax at (800) 472-5555 or Electronic Specialists Inc. at (800) 225-4876.

Caution: When warm air comes in contact with cold surfaces, such as outside walls and conduits, it causes condensation. To prevent condensation from accumulating inside the **E-30-PT** always bring conduit into the bottom of the unit. If this is not possible, drill a 1/4" diameter hole in the bottom of the gray plastic box.

***Note:** Peel off paper liner and adhere gasket to the back of the faceplate, centering it over the four corner mounting holes. Be careful to position the modular jack inside the chassis as not to damage the components on the circuit board.

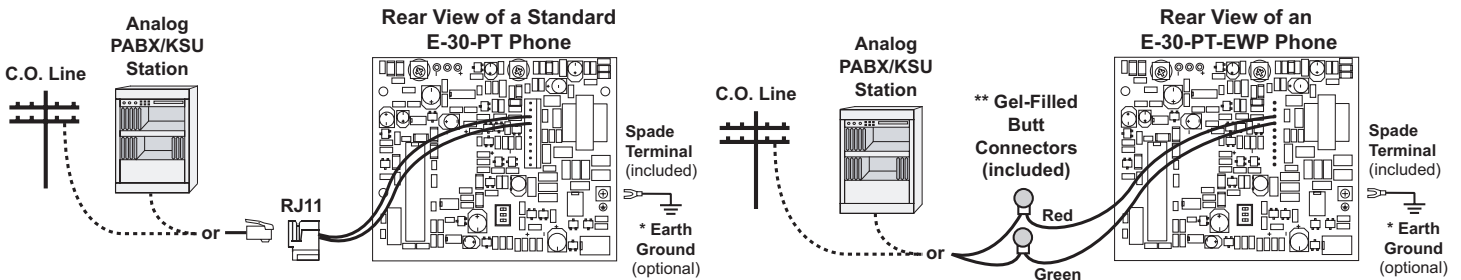
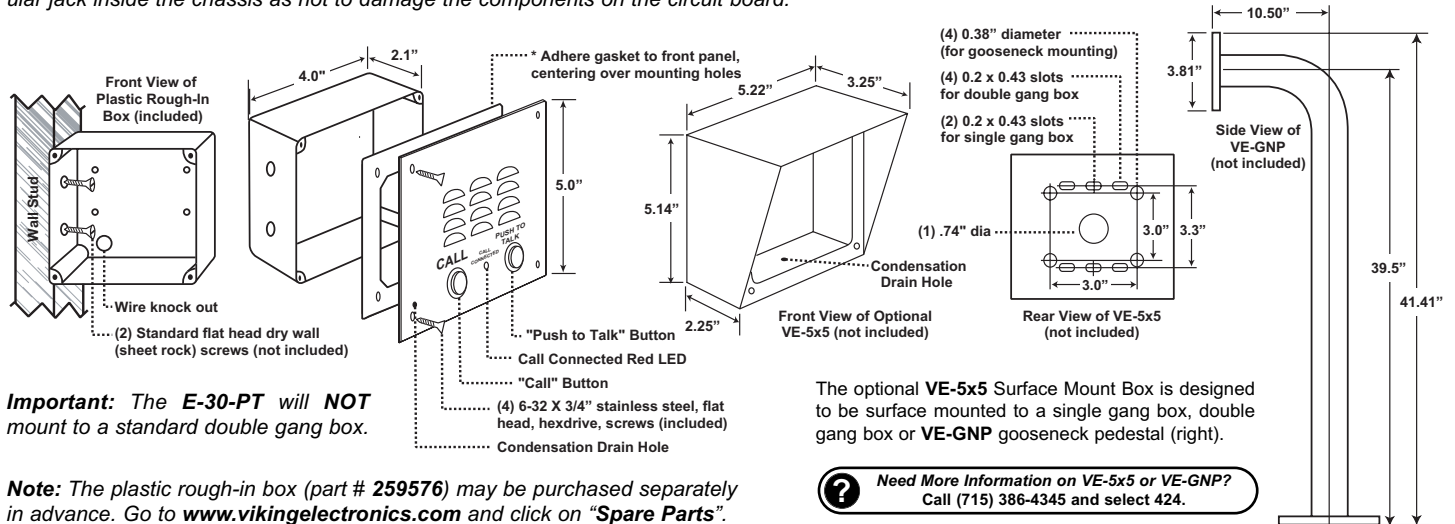

Programming

A. Accessing the Programming Mode

The **E-30-PT** phone can be programmed from any Touch Tone phone using a C.O. line, analog PABX/KSU station, or a **DLE-200B** Line Simulator.

? Need More Information on the DLE-200B?
Call (715) 386-4345 and select 605.

1. Using the Security Code

Step 1.	Move DIP switch 2 to the ON position (sets unit to answer incoming calls - see section F).
Step 2.	From a Touch Tone phone call the line attached to the E-30-PT .
Step 3.	When the E-30-PT answers, enter the 6-digit security code (factory set to 845464 - see section C). A double beep should then be heard indicating you have entered the programming mode.

2. Without the Security Code

Step 1.	Move DIP switch 2 to the ON position (sets unit to answer incoming calls - see section F).
Step 2.	Move DIP switch 3 to OFF (incoming calls enter the programming mode without security code - see section F).
Step 3.	From a Touch Tone phone call the line attached to the E-30-PT .
Step 4.	When the E-30-PT answers, a double beep will be heard and you will automatically enter the programming mode.
Step 5.	When finished programming, move DIP switch 3 back to the ON position (see section F).

Note: If a valid memory position is entered, a double beep will be heard, four beeps indicate an error.

B. Quick Programming Features

	Enter Digits	- then -	Enter Memory Location
First speed dial number	0-20 digits	then	#00
Second speed dial number	0-20 digits	then	#01
Third speed dial number	0-20 digits	then	#02
Fourth speed dial number	0-20 digits	then	#03
Fifth speed dial number	0-20 digits	then	#04
To add a * at any point in the dialing string	**		
To add a # at any point in the dialing string	*#		
To add a four second pause at any point in the dialing string	*7		
Toggle between Touch Tone and Pulse dialing	*6		
Timing/Dialing options (factory set to 234111)	6 digits (0-9)	then	#18
Change security code (factory set to 845464)	6 digits (0-9)	then	#19

C. Security Code (memory location #19)

The security code allows the user/installer to program the **E-30-PT** phone while DIP switch 3 is in the **ON** (normal) position. The factory set security code is 845464 (V-I-K-I-N-G). It is recommended that the factory set security code be changed. **Example:** To store 123456 as the security code:

Step 1.	Access programming as shown in Programming section A.
Step 2.	Enter 123456 #19..
Step 3.	Hang-up.

Enter Your Security Code Here:

						#19
--	--	--	--	--	--	------------

Note: The security code must be 6 digits and cannot include a * or a #.

D. Speed Dial Numbers (Memory Locations #00 - #04)

Note: Up to 20 digits can be stored in each dial position. Special features such as pause, mode change, Touch Tone * and # count as single digits.

The speed dial number programmed in location **#00** is the telephone or extension number that is dialed when the "Call" button is first pressed. Additional speed dial numbers will be dialed when there is no answer or a busy signal is detected and the next number redial features are activated. The **E-30-PT** will cycle through the programmed speed dial numbers until answered. To program, enter the desired speed dial number followed by the memory location number (**#00 - #04**).

To clear a speed dial location, simply enter the memory location (**#00 - #04**) alone. The **E-30-PT** is factory set with no speed dial number programmed.

To Program:	Enter:
*	**
#	*#
4 second pause	*7
switch to pulse mode	*6
0, 1, 2...9	0, 1, 2...9

E. Timing/Dialing Options (Memory Location #18)

There are six positions in the timing/dialing options. To program these options, enter the six desired timing/dialing digits followed by **#18**. The six available timing/dialing options are defined as shown below.

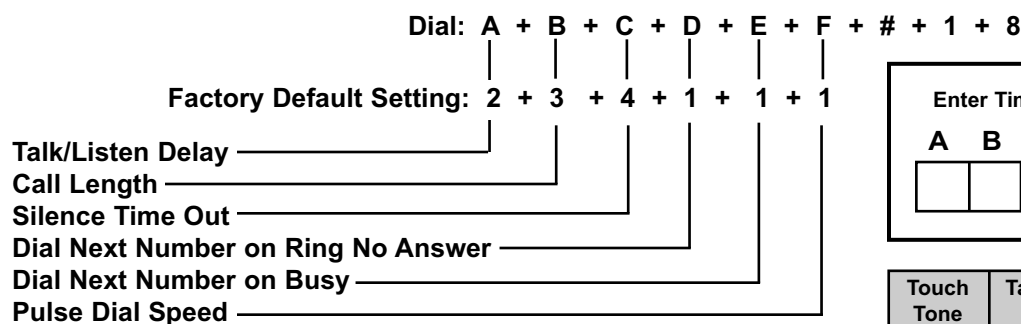

Enter Timing/Dialing Settings Here:

A	B	C	D	E	F	#18

Touch Tone	Talk/Listen Delay
1	.1 sec
2	.2 sec *
3	.3 sec
4	.4 sec
5	.5 sec
6	.6 sec
7	.7 sec
8	.8 sec
9	.9 sec

Setting A - Talk/Listen Delay

This feature selects switching time between talk and listen modes (VOX switching time). Use chart at the right. * **Note:** The factory default is .2 seconds.

Setting B - Call Length Time Out

This feature selects the maximum length of time that calls can be connected. Programmable in increments of 1 minute up to a maximum of 9 minutes (Touch Tones 1 - 9). Program 0 in this location to disable the call length time out. With the call length disabled, the **E-30-PT** phone must rely on CPC, busy, silence or return dialtone to hang-up. Use chart at the far right. * **Note:** The factory default is 3 minutes.

Touch Tone	Call Length Time Out
0	Disabled
1	1 min
2	2 min
3	3 min*
4	4 min
5	5 min
6	6 min
7	7 min
8	8 min
9	9 min

Setting C - Silence Time Out

This feature selects the length of time that calls will remain connected without voice activity. Programmable in increments of 10 seconds up to a maximum of 90 seconds (Touch Tones 1 - 9). To disable the silence time out, program 0 in this location. Use chart at the right.

* **Note:** The factory default is 40 seconds.

Touch Tone	Silence Time Out
0	Disabled
1	10 sec
2	20 sec
3	30 sec
4	40 sec*
5	50 sec
6	60 sec
7	70 sec
8	80 sec
9	90 sec

Setting D - Dial Next Number on Ring No Answer

If enabled and a ring-no-answer is detected, the E-30-PT phone will dial the next programmed speed dial number, and continue to cycle through the emergency numbers until a call is completed. * **Note:** This feature is disabled in the factory default.

Touch Tone	Setting D
1 or 0	Disabled*
2, 3, 4...9	Dials second number after 2, 3, 4...9 rings respectively

Setting E - Dial Next Number on Busy

If enabled and a busy is detected, the E-30-PT phone will dial the next programmed speed dial number, and continue to cycle through the emergency numbers until a call is completed. * **Notes:** This feature is disabled in the factory default setting. If the busy signal is interrupted with a promotional message, contact your central office to have it removed.

Touch Tone	Setting E
1	Disabled*
2	Enabled

Setting F - Pulse Dialing Rate (Pulses per Second)

The E-30-PT phone is capable of different pulse dialing speeds. * **Note:** The factory default setting is 10pps (pulses per second).

Touch Tone	Setting F
1	10 pps*
2	20 pps

F. DIP Switch Programming/Speaker and Microphone Adjustments

Two POTs are provided to increase or decrease speaker volume and microphone sensitivity. In certain noisy locations the microphone sensitivity may need to be decreased as shown below. **Caution:** Setting the microphone gain too high may cause distorted audio, prevent the distant party from breaking over and inhibit second number redialing.

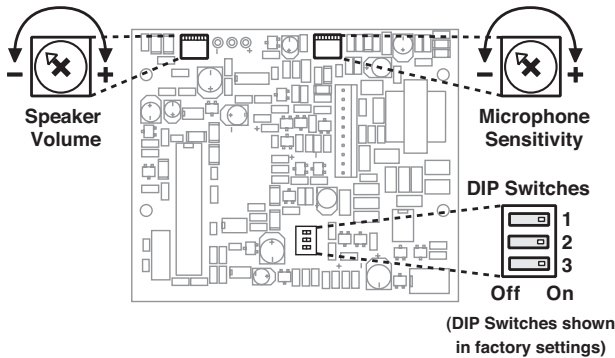

Switch	Position	Description
1	ON	"Call" button alternately connects and disconnects calls (factory setting)
1	OFF	"Call" button connects calls only
2	ON	Incoming calls answered (factory setting)
2	OFF	Incoming calls are not answered
3	ON	Normal operation mode (factory setting)
3	OFF	Learn mode - Any incoming calls are automatically entered into the programming mode (no security code required). Use this option if you have forgotten your security code.

G. Programming Examples

To Program the E-30-PT Phone...	Step 1 - See Section A	Step 2 - Enter Digits:
...to store 123456 as the security code	Enter Programming	1 2 3 4 5 6 # 1 9
...to store a Touch Tone 9, a four second pause and then a pulse dialed 333-4444 in the first speed dial position	Enter Programming	9 *7 *6 3 3 3 4 4 4 4 # 0 0
...to store 555-1234 in the second speed dial position	Enter Programming	5 5 5 1 2 3 4 # 0 1

Operation

When the "Call" button is pressed, the E-30-PT phone goes off-hook, and dials a pre-programmed telephone number. The front panel LED will light any time the phone is off hook. In the event that the line is busy or there is a ring-no answer, the unit can be programmed to call additional phone numbers. The phone then cycles through up to 5 pre-programmed speed dial numbers until the call is answered. Once answered, the called party will be able to hear the outside person, but at a very low level. When the outside person presses the "Push to Talk" button, his voice will then be heard at a normal level. The E-30-PT will hang up on CPC, silence, busy signal, return to dial tone, time out or Touch Tone command (*#). If programmed to auto-answer, the E-30-PT will also answer any incoming call.

Product Support Line...715.386.8666

Fax Back Line...715.386.4345

Due to the dynamic nature of the product design, the information contained in this document is subject to change without notice. Viking Electronics, and its affiliates and/or subsidiaries assume no responsibility for errors and omissions contained in this information. Revisions of this document or new editions of it may be issued to incorporate such changes.